

Battery operated Mini Hydraulic Cutter-Spreader

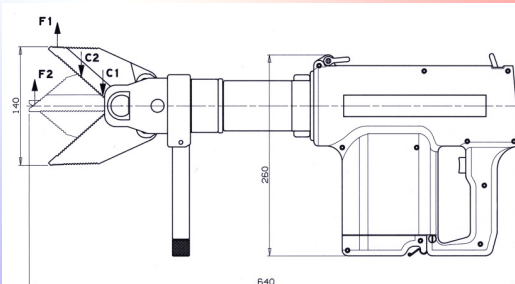

MADE IN FRANCE

▼ Self contained Mini Hydraulic Cutter-Spreader MCHA 140

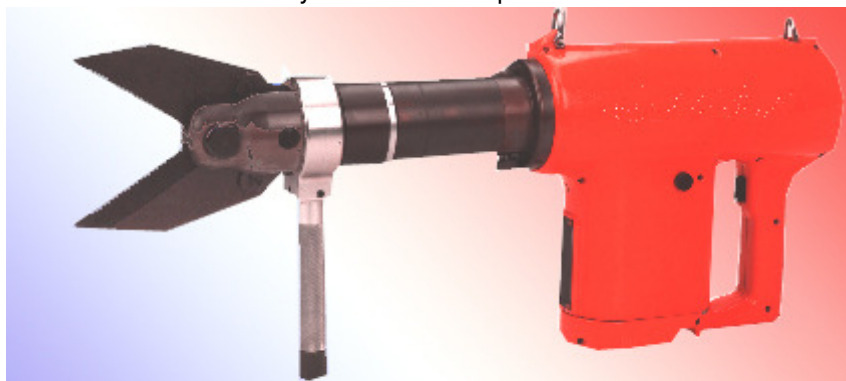

An ingenious tool
for rapid victim
rescue
operations in
airplane collision

DESCRIPTION

Autonomous hydraulic cutter –spreader comprising:

- 1 Double acting cylinder
- 1 Electric control
- 2 Cutting blades in hardened forged steel (4 blade models)
- 1 Holding handle
- 1 Unit in HR hardened light alloy
- 1 700 bar Hydraulic pump that can be used in all positions

Double effect spool valve, output 0.3 l/minute

- 1 24 volt, 245 watt motor, 3350 rpm
- 1 Battery pack, quick charge NIMH storage battery

Reserve time, 90 to 95 cycles at 700 B

- 1 Multi tension quick charge battery charger (2 h) 12/24 volts or 110/220V

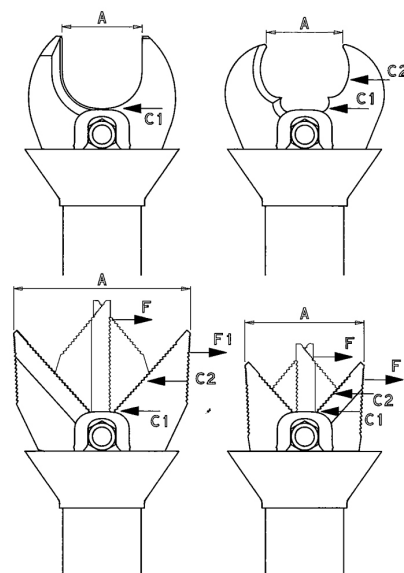

VARIANTS

MCHA140.1 :

- * 1 Foam lined carrying case containing:
- * 1 Hydraulic combi-tool
- * 1 Multi-voltage charger
- * 1 Spare battery pack
- * 1 Blade nut
- * 1 Size 24 spanner

MCHA140.2 :

- * MCHA140 1 +
- * 1 Spare blade set

CHARACTERISTICS

Model	MCHA100	MCHA140	MCHA60C	MCHA70U
Blade shapes	droites raccourcies	droites	courbes	en U
Operating pressure	700 bar	700 bar	700 bar	700 bar
Cutting force C1	190 kN	190 kN	157 kN	190 kN
Cutting force C2	102 kN	72 kN	88 kN	-
Spreading force F	20 kN	14 kN	-	-
Spreading force F1	23 kN	16 kN	-	-
Maximum opening A	98,5 mm	147 mm	66 mm	70 mm
Dimensions	602x104x260	640x104x260	609x104x260	612x104x260
Weight	9,7 kg	10 kg	10 kg	10 kg
Tool classification EN 13204	AC 58-C/ 9,7	AC 94-C/ 10	AC 66 -C/ 10	AC 70 -B/10

Powerful, Lightweight and Reliable in Rescue Operations

Battery operated Mini Hydraulic Cutter-Spreader



MADE IN FRANCE

▼ Self contained Mini Hydraulic Cutter-Spreader MCHA 200



An ingenious tool
for rapid victim
rescue
operations in
airplane collision

DESCRIPTION

Autonomous hydraulic cutter –spreader comprising:

- 1 Double acting cylinder
- 1 Electric control
- 2 Cutting blades in hardened forged steel (4 blade models)
- 1 Holding handle
- 1 Unit in HR hardened light alloy
- 1 700 bar Hydraulic pump that can be used in all positions

Double effect spool valve, output 0.3 l/minute

- 1 24 volt, 245 watt motor, 3350 rpm
- 1 Battery pack, quick charge NIMH storage battery

Reserve time, 90 to 95 cycles at 700 B

- 1 Multi tension quick charge battery charger (2 h) 12/24 volts or 110/220V

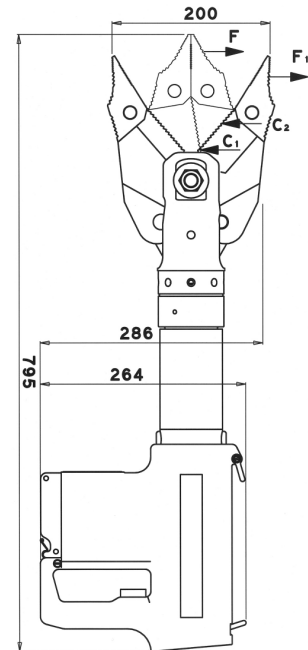

VARIANTS

MCHA 200.1 :

- * 1 Foam lined carrying case containing:
- * 1 Hydraulic combi-tool
- * 1 Multi-voltage charger
- * 1 Spare battery pack
- * 1 Blade nut
- * 1 Size 24 spanner

MCHA 200.2 :

- * MCHA200 1 +
- * 1 Spare blade set

CARACTERISTIQUES

Model	MCHA200
Blade shapes	En U
Operating pressure	700 bar
Cutting force C1	375 kN
Cutting force C2	159 kN
Spreading force F	26 kN
Spreading force F1	32 kN
Maximum opening A	202 mm
Dimensions	795x116x286
Weight	17,7 kg
Tool classification EN 13204	BC22,5/195-D-17,7

Powerful, Lightweight and Reliable in Rescue Operations